

# HORIZONTAL BALER

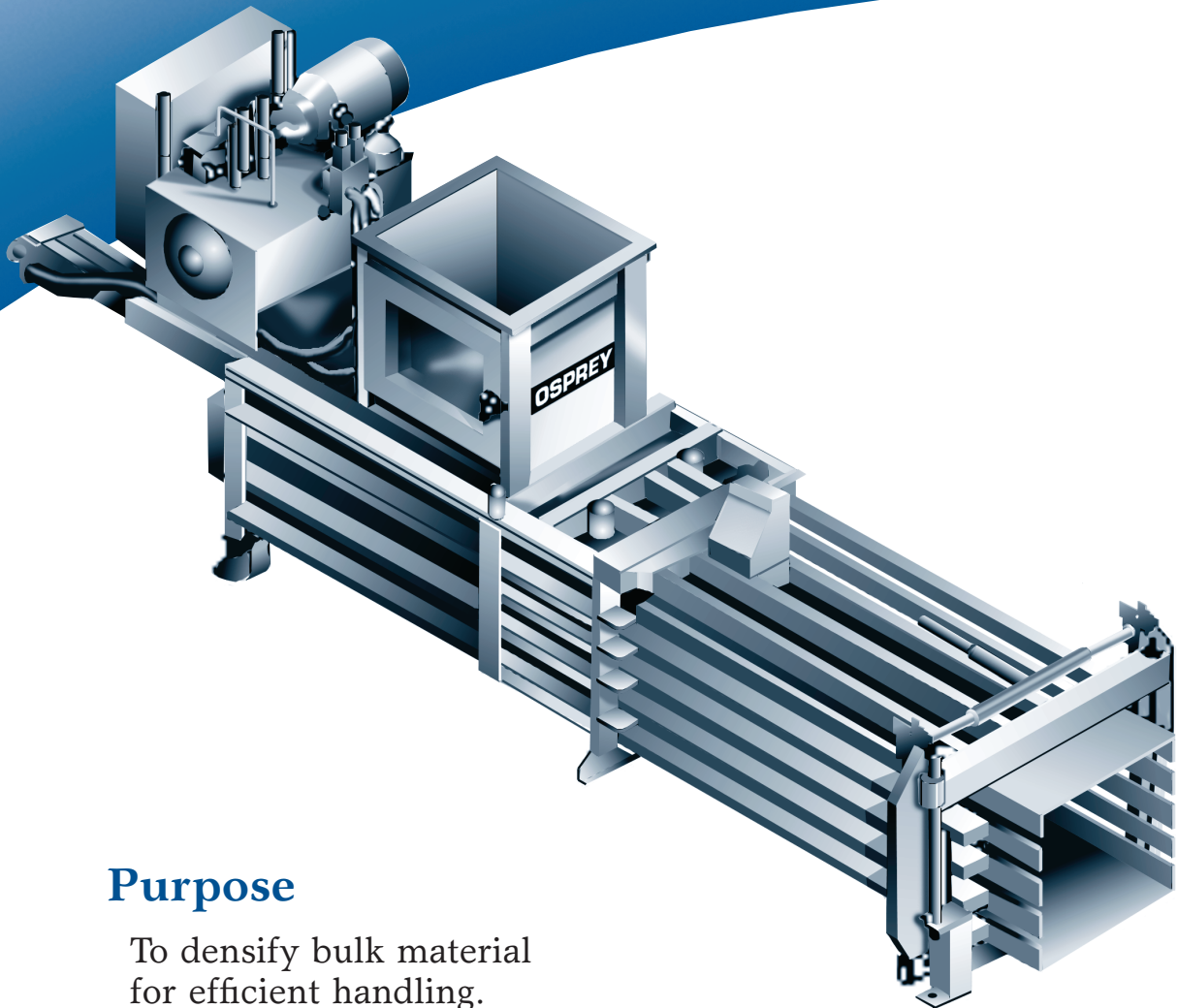

## Purpose

To densify bulk material  
for efficient handling.

## Application

Baling of paper, plastic,  
soft disposable products,  
edge trim, light metal,  
and most fibrous materials.



**OSPREY**  
CORPORATION

1835 Briarwood Road, NE Atlanta, Georgia 30329  
Tel: 404-321-7776 Fax: 404-634-1401  
[www.ospreyfilters.com](http://www.ospreyfilters.com)

# HORIZONTAL BALER

## Purpose

To densify bulk material for efficient handling.

## Application

Baling of paper, plastic, soft disposable products, edge trim, light metal, and most fibrous materials.

## Operation

Material fills the charging chamber and activates the hydraulic system. Once a bale has been formed, a dual signal alerts the operator to make a "single visit" bale tie-off. The tied bale extrudes from the end as the next bale is made. The baler is controlled by a programmable controller.

## Options

- Complete bale handling and storage systems.
- Automatic or manual feeding.
- Spare parts.
- Field service.
- Hydraulic fluid cooler.

## Features

- Factory assembled and tested.
- Adjustable bale length.
- Access door with window.
- Anti-jam sequence.
- No-leak hydraulic system.
- Open end design.

## Electrical

Pre-wired with motor starter for 20 h.p. (14.92 kw) hydraulic pump; Sonac level control; limit switches control the ram. Operates at world voltages and power cycles.

## Weight

Approximately 5,000 pounds (2272 kg.)

## Dimensions

Space Requirements: Recommended 30" (762 mm) clearance on each side (lengthwise). Recommended 20' (7m) on discharge end. Hydraulic cylinder end of the baler requires a minimum of 12' (3.7m) clearance.

