

Cyclone Auto Balance Assembly

Purpose

Eliminates the need to balance cyclones manually via slide gates while adjusting automatically to changes in process conditions.

Application

Stand-alone assembly mounts in existing duct work anywhere changes in process conditions justify rebalancing to maintain optimum performance.



Cyclone Auto Balance Assembly

Description

Eliminates the need to balance cyclones manually via slide gates while adjusting automatically to changes in process conditions. Reduces potential increases in cyclone emission levels associated with improperly balanced cyclones.

Application

Stand-alone assembly mounts in existing duct work anywhere changes in process conditions justify rebalancing to maintain optimum performance.

Operation

Complete stand-alone assembly is equipped with analog pressure transducer and electro-pneumatic actuated valve to throttle air flow maintaining the recommended static pressure in the system.

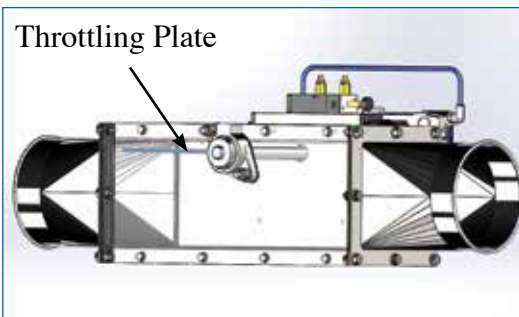

Standard

- Electro-pneumatic actuator
- Analog pressure transducer
- Quick Connection input/output block
- Output signal showing "in-balance"
- Ducting - quick connect or flanged
- 24 VDC power
- 100 psi (6.9 bar) clean and dry air

Options

High temperature version (< 400 deg F)

